

Aug. 28, 1956

T. E. ZEERIP

2,760,588

METHOD OF ADJUSTING A HELICOPTER BLADE TRAILING EDGE TAB

Filed Feb. 28, 1950

Fig. 1

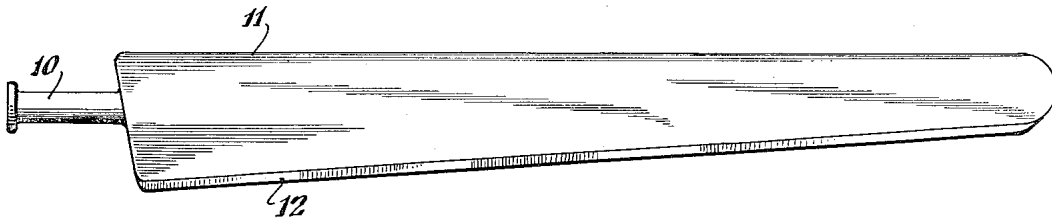

Fig. 2

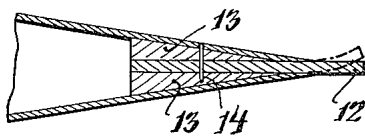

Fig. 3

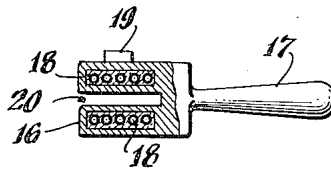

Fig. 5

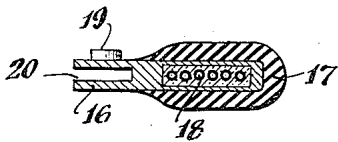

Fig. 4

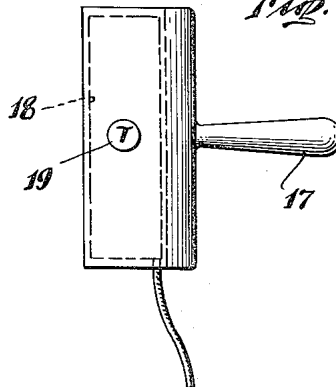
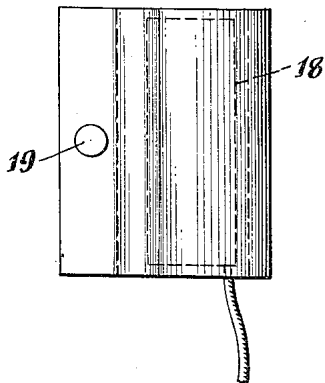

Fig. 6



INVENTOR.

Thomas E. Zeerip

BY

Bohler, Fassett & Montstream

ATTORNEYS

1

2,760,588

METHOD OF ADJUSTING A HELICOPTER BLADE TRAILING EDGE TAB

Thomas E. Zeerip, Ridgefield, Conn., assignor to Doman Helicopters, Inc., Danbury, Conn., a corporation of Delaware

Application February 28, 1950, Serial No. 146,703

2 Claims. (Cl. 170—160.24)

The invention relates to a helicopter rotor head blade having an adjustable tab at the trailing edge thereof for varying or changing the aerodynamic contour of the blade. Blades of a helicopter are provided with an adjustable or variable trailing edge in order to adjust the same and secure aerodynamic tracking of the blades.

It is an object of the invention to construct a blade having an adjustable tab, the adjustment of which is secured by heating the tab until it becomes soft or plastic and easily bendable without stressing the material beyond its elastic limit in order to secure a fixed adjustment of the tab.

Another object of the invention is the utilization of a trailing edge tab for a helicopter blade which is made of a thermoplastic material which upon heating at a relatively low temperature becomes plastic for easy bending or adjustment of the direction or plane of the tab.

Another object is to provide a tool for making the adjustment to the trailing edge tab.

Other objects of the invention will be more apparent from the following description when taken in connection with the accompanying drawings, illustrating a preferred embodiment of the invention, in which:

Figure 1 is a plan view of a helicopter blade;

Figure 2 is a cross section of the trailing edge of the blade on an enlarged scale;

Figure 3 is an end view of a tool for heating the tab to render the same plastic and bendable;

Figure 4 is a plan view of the tool of Figure 3;

Figure 5 is an end view of another form of heating tool; and

Figure 6 is a plan view of the tool of Figure 5.

Helicopter blades have been provided with a metallic tab or tabs embedded or secured in some fashion to the trailing edge of the blade bending of which was used to secure aerodynamic trailing or tracking of the blades. These metal tabs are manually bent by stressing the metal beyond its elastic limit so that the tab remains in adjusted or bent position. Before a blade is aerodynamically adjusted for tracking one point in the tab may be bent first in one direction and then as adjustment at other points in the blade change the tracking may require bending this point again either to its original straight position or so that it bends in a reverse direction. This may occur several times at some points before the blade is aerodynamically adjusted or matched. As a consequence the tab may be stressed too greatly and provide a fracture or at least a fatigue point where fracture will occur under the constant bending to which a blade is subjected in normal flight. In addition a metal tab is difficult to bend smoothly, is easily damaged in handling either separately or on the ship and is difficult to obtain secure fastening upon the trailing edge of the blade.

The invention herein utilizes an adjustable tab in the trailing edge of the helicopter blade which is thermoplastic at relatively low temperatures. The blade includes a spar 10 to which an aerodynamic body 11 is secured of

2

any desired shape and construction. A tab 12 is secured to the trailing edge of the blade or body in any suitable fashion, that particularly illustrated being embedded between taper blocks 13 in the trailing edge of the blade structure and secured thereto by known adhesives used in the manufacture of the blade. Nails or screws may also be used if desired. For a new blade it is embedded in the trailing edge at the same time that the blade is glued together. The projecting portion of the tab is adjustable for aerodynamic tracking of the blades and in some places along the length of the tab it may be bent downwardly and at other places it may be bent upwardly. The tab extends preferably along the whole length of the trailing edge of the blade although it may extend along a lesser portion thereof. Preferably too, it is a continuous strip. If a relatively thick tab is used its trailing edge may be reduced to a narrow edge.

Synthetic resins or so called plastics provide thermoplastic materials which can be made soft and pliable or bendable by heating them to a relatively low temperature. That portion of the tab which projects beyond the blade body 11 or some portion thereof is heated to soften the trailing edge of the tab whereupon it can then be bent when in a plastic condition to the desired angle or position either upwardly or downwardly. Since the material has been heated to a plastic condition there is no stressing for the material beyond its elastic limit in order to fix the adjustment to the desired angle or position as with metal tabs. Such adjustment therefore can be made indefinitely or at least a great many times at any point without introducing any fixed stresses or causing internal fatigue of the material. There are many thermoplastic materials known to the synthetic plastic or resin art of which "nylon," is the preferred material for the trailing edge tab. Other suitable organic thermoplastic materials are plasticized cellulose acetate, plasticized polyvinyl chloride, halogenated rubber, cellulose acetate-butyrate, thermoplastic synthetic resins such as copolymer of vinyl chloride and vinyl acetate, e. g. "Vinylite" polymerized esters of acrylic acid, polystyrene, vinylidene chloride and the like. These materials become plastic or bendable upon heating to its respective temperature at which it becomes plastic which is under 400 degrees centigrade.

In order to adjust the thermoplastic trailing edge tab, the projecting portion or some portion thereof is heated to the temperature at which it becomes soft and pliable whereupon it is bent to the desired position whereupon the heat is removed and the tab remains in the adjusted position. Any means may be utilized to heat the tab to the proper temperature so that it may be bent. A convenient tool for this purpose is illustrated in Figures 3 through 6 which includes an electric heater 16 of U-shaped form with a handle 17 extending therefrom. An electric heating pad 18 is provided in each leg of the U and may have a thermostat 19 adjusted to give a predetermined heat depending upon the temperature at which the thermoplastic material becomes soft enough for easy bending and at which temperature, when the tool is removed, the tab remains in adjusted position. The tab 12 is inserted in the slot 20 formed by the U-shaped tool and the tab is retained therein until it is soft, whereupon the tab is bent and the tool removed. In this manner the tab is adjusted at any desired point in its length without stressing the particles of the material beyond their elastic limit in order to have the tab remain in adjusted position.

Another form of tool is illustrated in Figures 5 and 6 in which the heating pad is in the handle but its operation is like that of Figures 3 and 4. Like parts are given

the same numerals and hence this tool need not be described.

The thermoplastic trim tab has several advantages in addition to those referred to hereinbefore including more simplified means or method of installation and it is easier to adjust. Also the tab is unaffected by corrosion and weather.

The invention also embodies a method of adjusting a trailing edge tab for a helicopter rotor head blade by heating the tab to a temperature which renders it plastic and pliable or bendable without stressing the same beyond its elastic limit and to such a temperature depending upon the material used that upon removing the heat it remains in its adjusted or bent position. The adjacent portions of the tab which are not heated tend to support the heated portion so that it will remain in adjusted position. The length of the heated portion may be selected as desired by the length of the heating device or tool.

Although the tab or tab means is preferably a continuous strip, it may comprise separate sections of desired length at least in the portion thereof which extends or projects beyond the body of the wing.

This invention is presented to fill a need for improvements in a helicopter blade with trailing edge tab. It is understood that various modifications in structure, as well as changes in mode of operation, assembly, and manner of use, may and often do occur to those skilled in the art, especially after benefiting from the teachings of an invention. Hence, it will be understood that this disclosure is illustrative of preferred means of embodying the invention in useful form by explaining the construction, operation and advantages thereof.

What is claimed is:

1. A method of adjusting a trailing edge tab means of a helicopter rotor head blade which projects from the trailing edge of the blade body and is of organic thermoplastic material comprising heating at least some portion of the thermoplastic tab means which projects beyond the blade body and which is to be bent to the temperature at which it becomes plastic, bending this portion of the tab means when plastic, and removing the heat therefrom whereupon the bent portion remains in bent position.

2. A method of adjusting a trailing edge tab as in claim 1 by heating and bending other projecting portions of the thermoplastic tab means which is to be bent.

References Cited in the file of this patent

UNITED STATES PATENTS

1,541,375	Neuwirth et al. -----	June 9, 1925
1,609,110	Brown -----	Nov. 30, 1929
1,754,993	Fenton -----	Apr. 15, 1930
1,843,886	Semmes -----	Feb. 2, 1932
1,990,291	Larsen -----	Feb. 5, 1935
2,323,165	Thomas -----	June 29, 1943
2,335,296	Miller -----	Nov. 30, 1943
2,417,586	Crosley -----	Mar. 18, 1947
2,470,854	Kovac -----	May 24, 1949
2,473,134	Bonnet -----	June 14, 1949
2,514,092	Reese -----	July 4, 1950
2,659,444	Stanley -----	Nov. 17, 1953